



QUAD-CHO-2x1-PB

Quad 2x1 3G/HD/SD-SDI Change-over
with Passive Input Bypass

User manual

Rev. D

A large, solid green circular graphic with a white circular cutout in the center, located in the bottom right corner of the page.

Nevion
Lysaker Torg 5
1366 Lysaker
Norway
Tel: +47 33 48 99 99
nevion.com

Nevion Support

Nevion AS

Lysaker Torg 5
1366 Lysaker, Norway

Support phone 1: +47 33 48 99 97
Support phone 2: +47 90 60 99 99

Nevion USA

400 West Ventura Boulevard, Suite 155,
Camarillo, CA 93010, USA

Toll free North America: (866) 515-0811
Outside North America: +1 (805) 247-8560

E-mail: support@nevion.com

See <http://www.nevion.com/support/> for service hours for customer support globally.

Revision history

Current revision of this document is the uppermost in the table below.

Rev.	Repl.	Date	Sign	Change description
D	C	2017-12-19	MR	Added new chapter; 4.4 Passive input bypass (-PB) In chapter 4.2 Terminal format support: Removed listing of SMPTE 310.
C	B	2017-11-17	MR	2.2 Electrical SDI inputs; changed min. cable lengths for all formats to be in accordance with current datasheet.
B	A	2017-10-02	MR	Corrected value of saturation voltage in 2.4 Open drain GPIOs Corrected descriptions of GPIO functions in the following chapters; 4.2, 4.3, 5.1.2. Added information under chapter 3.1 Multicon Gyda configuration concerning new function "Switching behavior".
A	-	2017-07-14	GAJ/MR	Initial version

Contents

Revision history	2
1 Product overview	4
1.1 Product versions	4
2 Specifications	5
2.1 General	5
2.2 Electrical SDI inputs	5
2.3 Electrical SDI outputs	6
2.4 Open drain GPIOs.....	6
2.5 Features.....	7
2.6 Supported standards.....	7
3 Configuration	8
3.1 Multicon GYDA configuration	8
3.1.1 Card label.....	9
3.1.2 Firmware upgrade	9
3.1.3 Electrical inputs	9
3.1.4 Reclockers	9
3.1.5 Electrical outputs.....	10
3.1.6 Automatic change-overs.....	10
3.2 Configuration through DIP settings.....	12
3.2.1 Selection of power supply.....	13
3.3 Hot swap.....	13
4 Connections	14
4.1 Mounting the connector module	14
4.2 Terminal format support	15
4.3 GPIO connections	16
4.4 Passive input bypass (-PB)	16
5 Operation.....	17
5.1 Module status.....	17
5.1.1 Multicon GYDA status interface.....	17
5.1.2 GPIO ALARM – Module Status Outputs	18
5.1.3 Front panel - Status monitoring	18
General environmental requirements for Nevision equipment	20
Product Warranty.....	21
Appendix A Materials declaration and recycling information	22
A.1 Materials declaration.....	22
A.2 Recycling information.....	22

1 Product overview

The QUAD-CHO-2x1-PB is a quad 2x1 3G/HD/SD-SDI change-over with passive input bypass well suited for quad stream UHD/4K applications.

The card can operate as either four independent change-overs or a quad stream change-over switching all 4 streams simultaneously. When operated in quad stream mode the card will make a switch on loss of signal or lock on any of the inputs, and the signal alarming will be given on the combined stream. The card monitors signal presence and lock of both main and backup inputs.

A passive relayed bypass of all four main inputs enables signal pass-thru in case of mains or card failure.

The Flashlink element manager Multicon enables web and SNMP interface for configuring card settings and monitoring signal status.

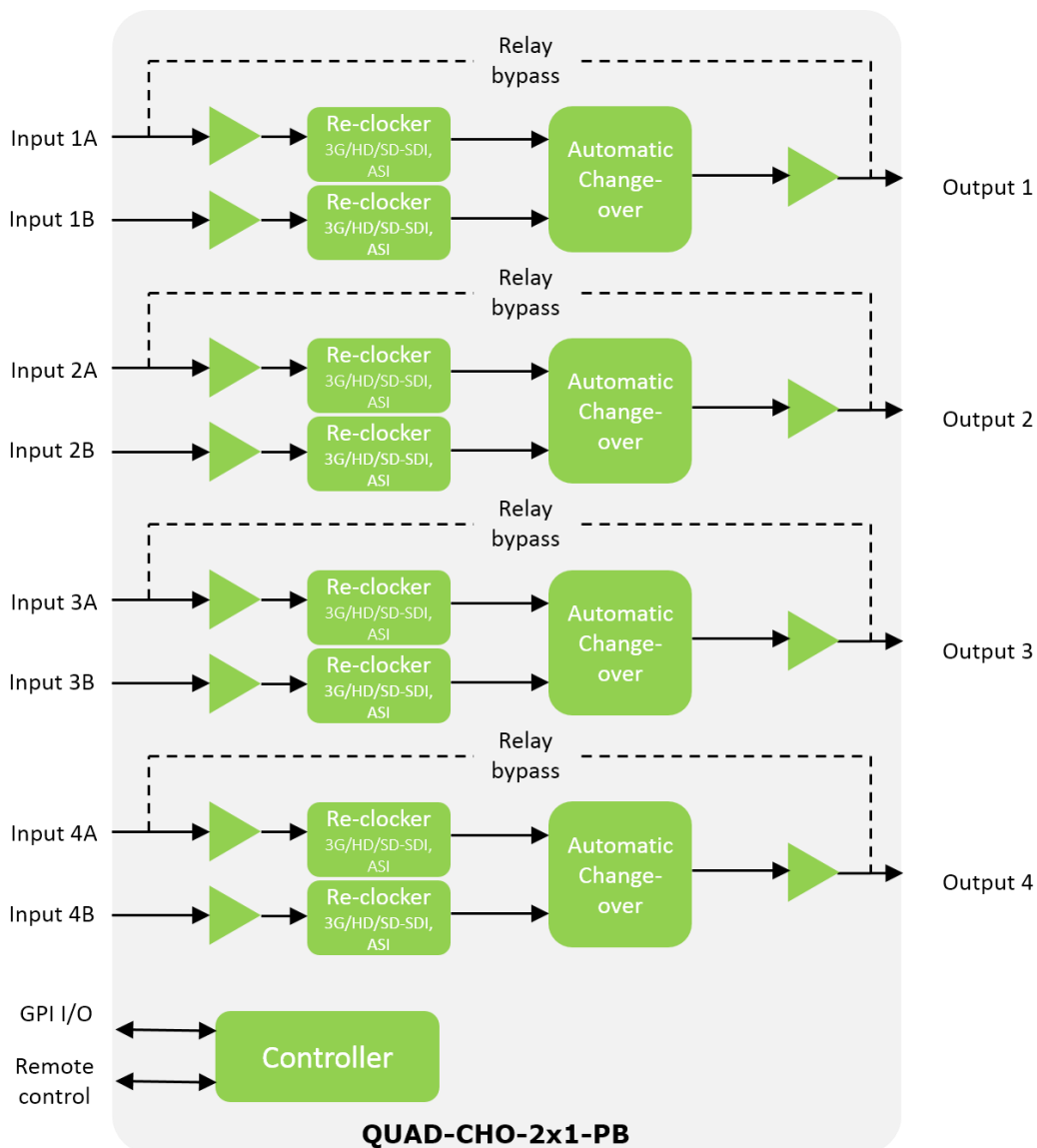

Figure 1: Block diagram of the QUAD-CHO-2x1-PB

1.1 Product versions

There are two connector backplane versions, one with DIN 1.0/2.3 and one with HD-BNC connectors.

2 Specifications

2.1 General

Power (DC)	+5 V / +15 V (Configurable DIP switch setting) 4.0 W / +5 V, 0.6 W / +15 V maximum (+5V DIP set) 3.6 W / +5 V, 0.6 W / +15 V typical (+5V DIP set) 4.6W / +15V maximum (+15V DIP set) 4.2W / +15V typical (+15V DIP set)
User interface	Status LED, Status GPIOs, configuration DIP switches Web interface and SNMP thru Multicon controller
Operating environmental temperature	0 to +45 °C

2.2 Electrical SDI inputs

Number of inputs	8, 4 relay protected
Data rate	125 Mbps – 2970 Mbps
Connectors	75 Ohm, DIN 1.0/2.3 or HD-BNC (depends on backplane type)
Input Return loss	< -15 dB, 5 MHz – 1.5 GHz < -10 dB, 1.5 GHz – 3 GHz
Jitter tolerance	SD limit: 10 Hz – 10 kHz: > 1 UI 10 kHz – 10 MHz: > 0.2 UI HD limit: 10 Hz – 10 kHz: > 1 UI 10 kHz – 10 MHz: > 0.2 UI 3G limit: 10 Hz – 10 kHz: > 2 UI 10 kHz – 10 MHz: > 0.3 UI
Equalized cable lengths (BER < 10E-12)	SD: 280m min. 300m typ. (Belden 8281) 400m min. 450m typ. (Belden 1694A)
Checkfield pattern	HD:
Unused outputs terminated with 75 ohm terminators	90m min. 100m typ. (Belden 1694A) 3G: 50m min. 55m typ. (Belden 1694A)
Remark	The I-xA input signals pass through relays resulting in degraded levels and rise/fall time equivalent to 15 meters of 1694A cable. The cable lengths above include this.

2.3 Electrical SDI outputs

Number of outputs	4, relay protected
Connectors	75 Ohm, DIN 1.0/2.3 or HD-BNC (depends on backplane type)
Output Return loss	< -15 dB, 5 MHz – 1.5 GHz < -10 dB, 1.5 GHz – 3 GHz
Output signal level (Launch level)	800 mV +/- 10%
Output signal rise / fall time (Launch values) (20% - 80 %)	- SD limit: [0.4 ns – 1.5 ns]; < 0.5 ns rise/fall variation - HD limit: < 270 ps, < 100 ps rise/fall variation - 3G limit: < 135 ps, < 50 ps rise/fall variation
Remark	Due to Nevia's design philosophy with use of passive backplanes the output signals pass significant PCB trace lengths between the cable drivers and output ports. This will result in significant degradation of levels and rise/fall times at HD and 3GHD at the backplane connectors compared to the listed specifications above which state launch levels at the cable drivers. The degradation equals approximately 10m meters of 1694A cable.
Remark	The O-xA outputs pass through relays resulting in degraded levels and rise/fall time equivalent to additional 5 meters of 1694A cable.
Amplitude overshoot/undershoot	< 10%
Polarity	All non-inverting (DVB-ASI compliant)
Output timing jitter	SD: < 0.2 UI HD: < 1 UI 3G: < 1 UI
Output alignment jitter	SD: < 0.15 UI HD: < 0.15 UI 3G: < 0.2 UI

2.4 Open drain GPIOs

Connector	PTSA 0,5 mm ² Push-in spring wire connector
No of ports	4
Applied voltage (DC)	25 V max.
Permitted current drain in output "low" state	150 mA max.
Saturation voltage at max. permitted current drain	600 mV max.

2.5 Features

Re-clocking:	Automatic SD, HD and 3GHD detection Automatic output slew rate adjustment according to SMPTE- 259M, SMPTE-292 and SMPTE424M
Supported clock rates:	125Mbps, 270Mbps, 1.485 and 1.485/1.001Gbps, 2.97 and 2.97/1.001Gbps
MADI:	According to AES10 with the following exemption; Amplitude and rise and fall times according to SD-SDI (SMPTE- 292M) at electrical outputs.
Automatic change over:	Quad 2x1 blocks with independent (4x3G) or Quad (UHD/4K) function. Choice of "Main" input in Auto mode, or fixed input in manual mode. Selectable Rule switching criteria; - Loss of signal (Los) - Loss of lock (Lol)

2.6 Supported standards

SMPTE:	SMPTE259M, SMPTE292 and SMPTE424M
DVB-ASI:	EN50083-9
MADI:	AES10

3 Configuration

Configuration of this card can either be done from Multicon GYDA element manager or locally on the card by DIP switches.

3.1 Multicon GYDA configuration

Below is a snapshot from the Multicon GYDA interface.

Quad CHO 2x1 with Passive Bypass

Card label	<input type="text"/>	Locate card	<input type="text"/>	sec
Firmware upgrade	Upload file: <input type="text" value="None"/>	<input type="button" value="Upload"/>		
Electrical input I-1A	<input checked="" type="radio"/> Normal <input type="radio"/> Bypass			
Electrical input I-2A	<input checked="" type="radio"/> Normal <input type="radio"/> Bypass			
Electrical input I-3A	<input checked="" type="radio"/> Normal <input type="radio"/> Bypass			
Electrical input I-4A	<input checked="" type="radio"/> Normal <input type="radio"/> Bypass			
Electrical input I-1B	<input checked="" type="radio"/> Normal <input type="radio"/> Bypass			
Electrical input I-2B	<input checked="" type="radio"/> Normal <input type="radio"/> Bypass			
Electrical input I-3B	<input checked="" type="radio"/> Normal <input type="radio"/> Bypass			
Electrical input I-4B	<input checked="" type="radio"/> Normal <input type="radio"/> Bypass			
Reclocker channel 1	<input checked="" type="radio"/> Enable <input type="radio"/> Bypass	Autobypass:	<input checked="" type="radio"/> On	<input type="radio"/> Off
Reclocker channel 2	<input checked="" type="radio"/> Enable <input type="radio"/> Bypass	Autobypass:	<input checked="" type="radio"/> On	<input type="radio"/> Off
Reclocker channel 3	<input checked="" type="radio"/> Enable <input type="radio"/> Bypass	Autobypass:	<input checked="" type="radio"/> On	<input type="radio"/> Off
Reclocker channel 4	<input checked="" type="radio"/> Enable <input type="radio"/> Bypass	Autobypass:	<input checked="" type="radio"/> On	<input type="radio"/> Off
Automatic change-over 1	Mode: <input type="text" value="Auto"/>	Main:	<input type="radio"/> El input I-1A	<input checked="" type="radio"/> El input I-1B
Automatic change-over 2	Mode: <input type="text" value="Auto"/>	Main:	<input type="radio"/> El input I-2A	<input checked="" type="radio"/> El input I-2B
Automatic change-over 3	Mode: <input type="text" value="Auto"/>	Main:	<input type="radio"/> El input I-3A	<input checked="" type="radio"/> El input I-3B
Automatic change-over 4	Mode: <input type="text" value="Auto"/>	Main:	<input type="radio"/> El input I-4A	<input checked="" type="radio"/> El input I-4B
Automatic change-over function	<input type="radio"/> Quad (UHD/4K) <input checked="" type="radio"/> Independent			
Switching behaviour	<input checked="" type="radio"/> Defined break <input type="radio"/> Immediate			
Electrical output O-1A/B			Slewrate:	<input checked="" type="radio"/> Auto <input type="radio"/> SD <input type="radio"/> HD
Electrical output O-2A/B			Slewrate:	<input checked="" type="radio"/> Auto <input type="radio"/> SD <input type="radio"/> HD
Electrical output O-3A/B			Slewrate:	<input checked="" type="radio"/> Auto <input type="radio"/> SD <input type="radio"/> HD
Electrical output O-4A/B			Slewrate:	<input checked="" type="radio"/> Auto <input type="radio"/> SD <input type="radio"/> HD

Alarm	Lower limit	Upper limit	Alarm	SNMP trap
Electrical input I-1A			<input checked="" type="radio"/> Normal <input type="radio"/> Ignore	<input type="radio"/> Send <input checked="" type="radio"/> Ignore
Electrical input I-2A			<input checked="" type="radio"/> Normal <input type="radio"/> Ignore	<input type="radio"/> Send <input checked="" type="radio"/> Ignore
Electrical input I-3A			<input checked="" type="radio"/> Normal <input type="radio"/> Ignore	<input type="radio"/> Send <input checked="" type="radio"/> Ignore
Electrical input I-4A			<input checked="" type="radio"/> Normal <input type="radio"/> Ignore	<input type="radio"/> Send <input checked="" type="radio"/> Ignore
Electrical input I-1B			<input checked="" type="radio"/> Normal <input type="radio"/> Ignore	<input type="radio"/> Send <input checked="" type="radio"/> Ignore
Electrical input I-2B			<input checked="" type="radio"/> Normal <input type="radio"/> Ignore	<input type="radio"/> Send <input checked="" type="radio"/> Ignore
Electrical input I-3B			<input checked="" type="radio"/> Normal <input type="radio"/> Ignore	<input type="radio"/> Send <input checked="" type="radio"/> Ignore
Electrical input I-4B			<input checked="" type="radio"/> Normal <input type="radio"/> Ignore	<input type="radio"/> Send <input checked="" type="radio"/> Ignore
Automatic change-over 1			<input checked="" type="radio"/> Normal <input type="radio"/> Ignore	<input type="radio"/> Send <input checked="" type="radio"/> Ignore
Automatic change-over 2			<input checked="" type="radio"/> Normal <input type="radio"/> Ignore	<input type="radio"/> Send <input checked="" type="radio"/> Ignore
Automatic change-over 3			<input checked="" type="radio"/> Normal <input type="radio"/> Ignore	<input type="radio"/> Send <input checked="" type="radio"/> Ignore
Automatic change-over 4			<input checked="" type="radio"/> Normal <input type="radio"/> Ignore	<input type="radio"/> Send <input checked="" type="radio"/> Ignore
Voltage (5V)	4500 mV	5500 mV	<input checked="" type="radio"/> Normal <input type="radio"/> Ignore	<input type="radio"/> Send <input checked="" type="radio"/> Ignore
Voltage (15V)	13500 mV	16500 mV	<input checked="" type="radio"/> Normal <input type="radio"/> Ignore	<input type="radio"/> Send <input checked="" type="radio"/> Ignore
Voltage (1.8V)	1600 mV	2000 mV	<input checked="" type="radio"/> Normal <input type="radio"/> Ignore	<input type="radio"/> Send <input checked="" type="radio"/> Ignore
Voltage (3.3V)	3000 mV	3600 mV	<input checked="" type="radio"/> Normal <input type="radio"/> Ignore	<input type="radio"/> Send <input checked="" type="radio"/> Ignore
Reclocker 1A			<input checked="" type="radio"/> Normal <input type="radio"/> Ignore	<input type="radio"/> Send <input checked="" type="radio"/> Ignore
Reclocker 2A			<input checked="" type="radio"/> Normal <input type="radio"/> Ignore	<input type="radio"/> Send <input checked="" type="radio"/> Ignore
Reclocker 3A			<input checked="" type="radio"/> Normal <input type="radio"/> Ignore	<input type="radio"/> Send <input checked="" type="radio"/> Ignore
Reclocker 4A			<input checked="" type="radio"/> Normal <input type="radio"/> Ignore	<input type="radio"/> Send <input checked="" type="radio"/> Ignore
Reclocker 1B			<input checked="" type="radio"/> Normal <input type="radio"/> Ignore	<input type="radio"/> Send <input checked="" type="radio"/> Ignore
Reclocker 2B			<input checked="" type="radio"/> Normal <input type="radio"/> Ignore	<input type="radio"/> Send <input checked="" type="radio"/> Ignore
Reclocker 3B			<input checked="" type="radio"/> Normal <input type="radio"/> Ignore	<input type="radio"/> Send <input checked="" type="radio"/> Ignore
Reclocker 4B			<input checked="" type="radio"/> Normal <input type="radio"/> Ignore	<input type="radio"/> Send <input checked="" type="radio"/> Ignore
Card version				
hw	0.0			
lib	1.3.2			
sw	0.0.63			

Figure 2: Configuration tab example

Changing **Automatic change-over function** will trigger “Card lost” in Multicon GYDA so that graphics and text blocks in both Status tab and Configuration tab is updated. The module is not rebooted and will not interrupt other functions.

3.1.1 Card label

Card label	<input style="width: 95%;" type="text"/>	Locate card	<input style="width: 95%;" type="text"/>	sec
-------------------	--	-------------	--	-----

Figure 3: Card label

Assign a name to the Flashlink module, up to 31 characters. When the “locate card” button is pushed, all indicators/LED’s on the front of the module will flash for 120 seconds, alternatively a period can be entered into the sec box.

3.1.2 Firmware upgrade

Firmware upgrade	Upload file: <input style="width: 95%;" type="text" value="None"/>	Upload
-------------------------	--	--------

Figure 4: Firmware upgrade

Update the firmware on the Flashlink module. The firmware file first has to be uploaded to Multicon Gyda by ftp. See user manual for Multicon Gyda concerning help on uploading.

3.1.3 Electrical inputs

Electrical input I-1A	<input checked="" type="radio"/> Normal <input type="radio"/> Bypass	
Electrical input I-2A	<input checked="" type="radio"/> Normal <input type="radio"/> Bypass	
Electrical input I-3A	<input checked="" type="radio"/> Normal <input type="radio"/> Bypass	
Electrical input I-4A	<input checked="" type="radio"/> Normal <input type="radio"/> Bypass	
Electrical input I-1B	<input checked="" type="radio"/> Normal <input type="radio"/> Bypass	
Electrical input I-2B	<input checked="" type="radio"/> Normal <input type="radio"/> Bypass	
Electrical input I-3B	<input checked="" type="radio"/> Normal <input type="radio"/> Bypass	
Electrical input I-4B	<input checked="" type="radio"/> Normal <input type="radio"/> Bypass	

Figure 5: Electrical inputs

For SDI signals set the electrical input to “normal”. For non-supported signal formats “bypass” mode may be used. The cable equalizer will then be bypassed. This may give better performance since the cable equalizer is optimized for the supported standards.

3.1.4 Reclockers

Reclocker 1A	<input checked="" type="radio"/> Enable <input type="radio"/> Bypass	Autobypass: <input checked="" type="radio"/> On <input type="radio"/> Off
Reclocker 2A	<input checked="" type="radio"/> Enable <input type="radio"/> Bypass	Autobypass: <input checked="" type="radio"/> On <input type="radio"/> Off
Reclocker 3A	<input checked="" type="radio"/> Enable <input type="radio"/> Bypass	Autobypass: <input checked="" type="radio"/> On <input type="radio"/> Off
Reclocker 4A	<input checked="" type="radio"/> Enable <input type="radio"/> Bypass	Autobypass: <input checked="" type="radio"/> On <input type="radio"/> Off
Reclocker 1B	<input checked="" type="radio"/> Enable <input type="radio"/> Bypass	Autobypass: <input checked="" type="radio"/> On <input type="radio"/> Off
Reclocker 2B	<input checked="" type="radio"/> Enable <input type="radio"/> Bypass	Autobypass: <input checked="" type="radio"/> On <input type="radio"/> Off
Reclocker 3B	<input checked="" type="radio"/> Enable <input type="radio"/> Bypass	Autobypass: <input checked="" type="radio"/> On <input type="radio"/> Off
Reclocker 4B	<input checked="" type="radio"/> Enable <input type="radio"/> Bypass	Autobypass: <input checked="" type="radio"/> On <input type="radio"/> Off

Figure 6: Reclockers

For supported formats; set to enable, else it may be set to bypass. Autobypass only works if the reclocker is enabled. In “autobypass” mode the reclocker will bypass not supported formats.

3.1.5 Electrical outputs

Electrical output O-1A/B	Slewrate: <input checked="" type="radio"/> Auto <input type="radio"/> SD <input type="radio"/> HD
Electrical output O-2A/B	Slewrate: <input checked="" type="radio"/> Auto <input type="radio"/> SD <input type="radio"/> HD
Electrical output O-3A/B	Slewrate: <input checked="" type="radio"/> Auto <input type="radio"/> SD <input type="radio"/> HD
Electrical output O-4A/B	Slewrate: <input checked="" type="radio"/> Auto <input type="radio"/> SD <input type="radio"/> HD

Figure 7: Electrical outputs

With slew rate set to “Auto” the rise- and fall time of the cable driver will be automatically adjusted according to the actual signal format.

For bit rates below 270Mbps the slew rate is automatically set to SD slew rate.

For not supported signals with bitrates above 270Mbps the proper slew rate can be selected manually.

3.1.6 Automatic change-overs

3.1.6.1 General description

Automatic change-over 1	Mode: <input type="text" value="Auto"/> Main: <input type="radio"/> El input I-1A <input checked="" type="radio"/> El input I-1B
	Latch: <input type="radio"/> On <input checked="" type="radio"/> Off <input type="button" value="Reset"/> Hold time: <input type="text" value="50"/> ms Lock time: <input type="text" value="50"/> ms
	Rule: <input type="radio"/> Los <input checked="" type="radio"/> Lol
Automatic change-over 2	Mode: <input type="text" value="Auto"/> Main: <input type="radio"/> El input I-2A <input checked="" type="radio"/> El input I-2B
	Latch: <input type="radio"/> On <input checked="" type="radio"/> Off <input type="button" value="Reset"/> Hold time: <input type="text" value="50"/> ms Lock time: <input type="text" value="50"/> ms
	Rule: <input type="radio"/> Los <input checked="" type="radio"/> Lol
Automatic change-over 3	Mode: <input type="text" value="Auto"/> Main: <input type="radio"/> El input I-3A <input checked="" type="radio"/> El input I-3B
	Latch: <input type="radio"/> On <input checked="" type="radio"/> Off <input type="button" value="Reset"/> Hold time: <input type="text" value="50"/> ms Lock time: <input type="text" value="50"/> ms
	Rule: <input type="radio"/> Los <input checked="" type="radio"/> Lol
Automatic change-over 4	Mode: <input type="text" value="Auto"/> Main: <input type="radio"/> El input I-4A <input checked="" type="radio"/> El input I-4B
	Latch: <input type="radio"/> On <input checked="" type="radio"/> Off <input type="button" value="Reset"/> Hold time: <input type="text" value="50"/> ms Lock time: <input type="text" value="50"/> ms
	Rule: <input type="radio"/> Los <input checked="" type="radio"/> Lol
Automatic change-over function	<input type="radio"/> Quad (UHD/4K) <input checked="" type="radio"/> Independent
Switching behaviour	<input checked="" type="radio"/> Defined break <input type="radio"/> Immediate

Figure 8: Automatic change-overs at independent function

Automatic change-over	Mode: <input type="text" value="Auto"/> Main: <input type="radio"/> El input I-xA <input checked="" type="radio"/> El input I-xB
	Latch: <input type="radio"/> On <input checked="" type="radio"/> Off <input type="button" value="Reset"/> Hold time: <input type="text" value="50"/> ms Lock time: <input type="text" value="50"/> ms
	Rule: <input type="radio"/> Los <input checked="" type="radio"/> Lol
Automatic change-over function	<input checked="" type="radio"/> Quad (UHD/4K) <input type="radio"/> Independent
Switching behaviour	<input checked="" type="radio"/> Defined break <input type="radio"/> Immediate

Figure 9: Automatic change-overs in All (UHD/4K) function

Remark: It is highly recommended to avoid using Rule “Los” at 3GHD formats since crosstalk may cause false signal detect on adjacent input ports.

Automatic change-over function

The change-over function can be selected to:

- **Independent (4x3G)** – All change-overs are functioning independently.

- **Quad (UHD/4K)** – All change-overs switch simultaneously when any one or more of the Automatic change-overs triggers. In this mode, only “Automatic change-over 1” is available for configuration, and the configuration applies to all change-overs. If there are discrepancies at both A and B input signals, the input group (A/B) with the highest number of good signals will be chosen. If the number of good signals is equal, the input configured as “main” will be chosen.

Switching behaviour

Some equipment require a well defined break in signal stream at switching to function properly.

- Defined break – a break of approximately 1s duration is added at all switch operations
- Immediate – switching is performed as quick as the solution permits

Mode

The change-over mode can be set to:

- **Auto** – normal change-over function.
- **EI input I-xA** or **EI input I-xB** – manual fixed function.

Main

In Auto mode, main is configurable to either EI input I-xA or EI input I-xB. The other input will automatically be the backup input.

Latch

The latch can be set to:

- **Latch On** – When switched from main input to any backup input, only using the “Reset” button can change source back to main input
- **Latch Off** – No latch function activated

Hold time

Source changes from main input to backup input after a continuous error condition with duration exceeding the chosen hold time.

Minimum value to be used: 0ms Maximum value to be used: 4999ms

Lock time

Source changes from backup input to main input after a continuous error free period with duration exceeding the chosen lock time.

Minimum value to be used: 0ms Maximum value to be used: 4999ms

Rule

There are two optional settings for change-over criteria:

- Loss of signal (**Los**) – Source input changes if signal is lost in current input.
- Loss of lock (**Lol**) – Source input changes if reclocker lock is lost on current input.

There are four independent change over blocks where main input and backup input can be chosen.

When reclockers are in “Bypass” mode, “Lol” must not be used as change over criterion.

3.1.6.2 Describing figures

When the latch is set to “off”:

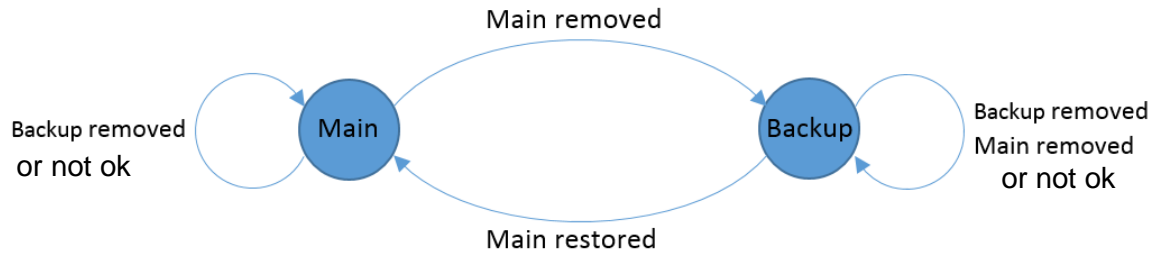

Figure 10: Latch Off

When the latch is set to “on”:

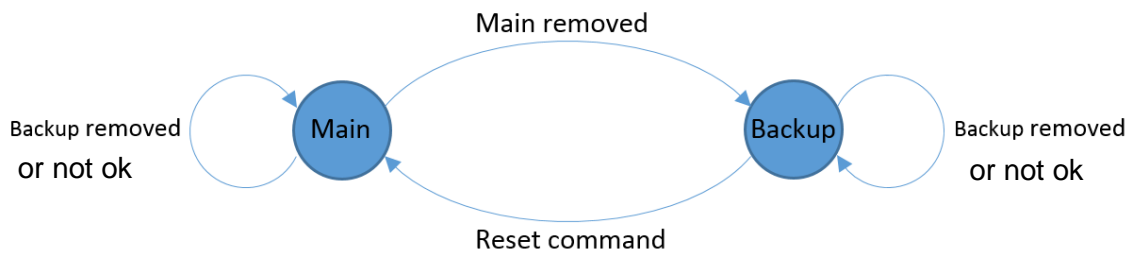

Figure 11: Latch On

3.2 Configuration through DIP settings

The correct configuration can either be set with the DIP switch on the card or through the GYDA Control System. The layout is shown in the drawing below with the DIP switch to the upper left position.

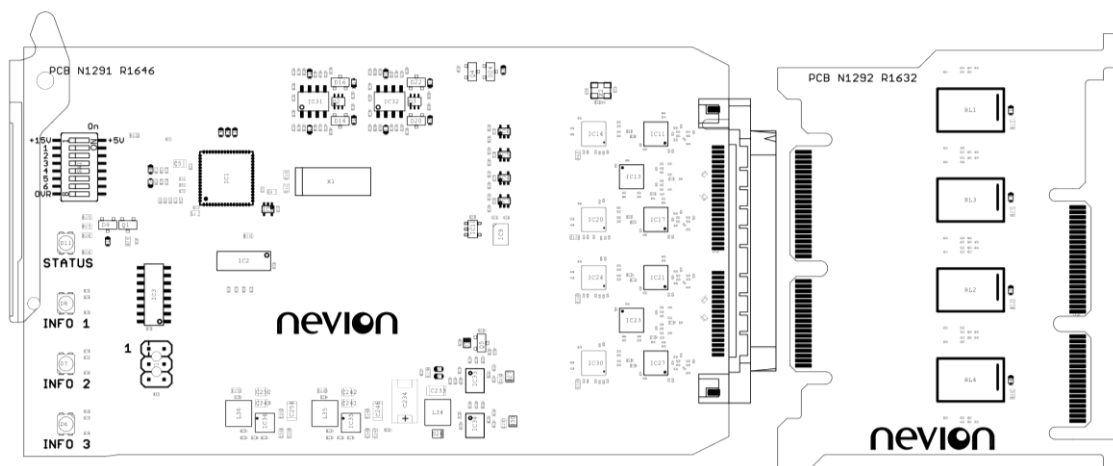

Figure 12: QUAD-CHO-2x1-PB board layout

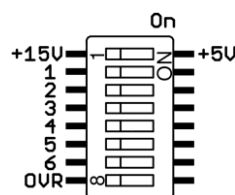

Figure 13: DIP switch

Table 1: DIP settings

Switch #	Label	Function, DIP=OFF	Function, DIP=ON	Comment
1	+15V	Board supplied by +15 V DC	Board supplied by +5 V DC	Selection of power Attention: Must only be operated when the board is unpowered
2	1	Input I-xA Main, Input I-xB Backup.	Input I-xA Backup, Input I-xB Main	Select Main/Backup for CHO
3	2	Loss of signal	Loss of lock	Signal integrity decision for CHO
4	3	Latch Off (Will automatically return to main when input signal is "good")	Latch On (Must be reset to return from standby to main)	"Sticky" switching. "good" is depending on switch criteria for CHO
5	4	Reclocker Bypass (Loss of lock will not work on this mode)	Reclocker ON	Reclocker mode
6	5	Cable Equalizer Bypass (Loss of signal will not work on this mode)	Cable Equalizer ON	Equalizer mode
7	6	Independent (4x3G)	Quad (UHD/4K)	Automatic change-over function
8	OVR	GYDA control. Config. with GYDA	Override GYDA control Config. with DIP switch	Select config. from GYDA

All DIP switches are off when pointing towards the release handle.

3.2.1 Selection of power supply

(Only DIP configurable)

The module can be configured to be powered from either +5 V or +15 V DC power rails with DIP switch labeled "+15V". This feature is useful to improve utilization of, or balancing the available power in a frame.

The DIP switch must only be operated when the board is unpowered to prevent instability.

The configuration is set to +5 V as default.

3.3 Hot swap

When a module is replaced by one unit with same configuration for "Automatic change-over function" (Quad (UHD/4K)/Independent), the new module will automatically be updated with the current configurations. However, if "Automatic change-over function" is configured differently for the two modules, the new module will be regarded as a different product, and configuration must be performed manually in Multicon.

4 Connections

The QUAD-CHO-2x1-PB has a dedicated backplane assembly; DA-CHO-C1 relay module combined with either -C2 or -C3 connector module. This assembly is mounted at the rear of the sub-rack. The layout of the connector module is shown in the figure below.

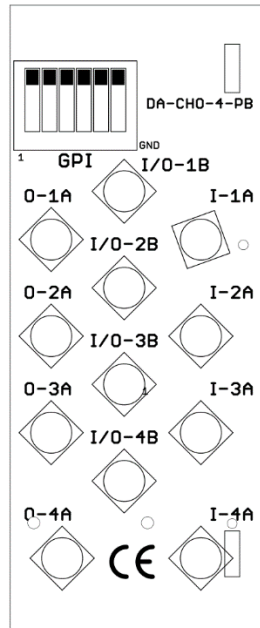

Figure 14: Backplane connector module for QUAD-CHO-2x1-PB

- Passive input bypass is connected through the *I-xA* to *O-xA* connectors respectively, where *x* is the stream number from 1 to 4.
- In QUAD-CHO-2x1-PB, the *I/O-xB* connectors are *I-xB* inputs, while in QUAD-DA-1x2-PB the *I/O-xB* connectors are *O-xB* outputs.

4.1 Mounting the connector module

Product consists of three main parts as seen in Figure 15.

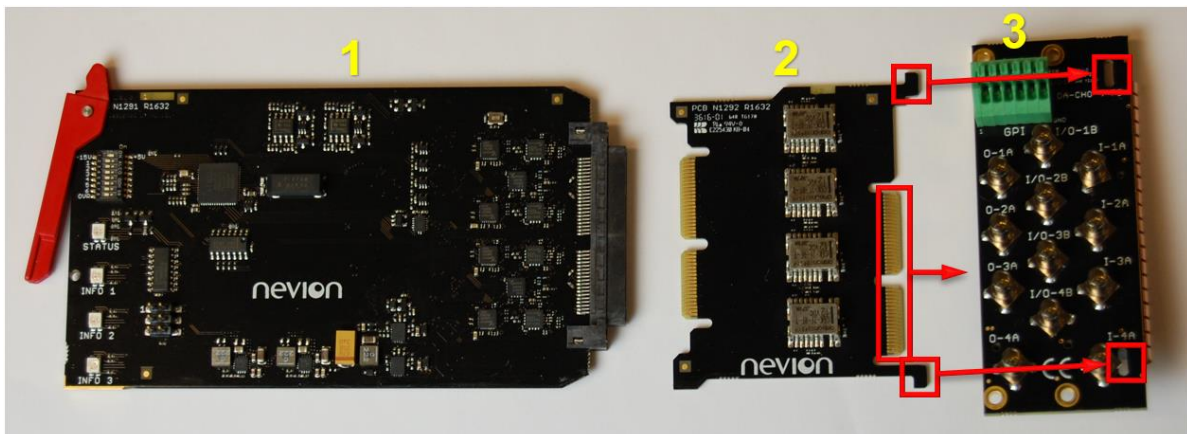

Figure 15: The three main parts of the product

Some assembly is needed before this can be installed into a frame:

1. Connect connector module (3, Figure 15) to relay module (2, Figure 15) and make sure the connectors are completely mated with the two guide pins located on top/bottom as seen in Figure 15.
2. Slide the assembled modules into the back of the frame while making sure the C1 board slides correctly into the frame's guide rail. Make sure the pins align and correctly connects to the power bus connector as seen in Figure 16.
3. Fasten the backplane with the supplied screws.

More details on how the connector module is mounted are found in the user manual for the sub-rack frame FR-2RU-10-2.

This manual is also available from our web site: <http://www.nevion.com>

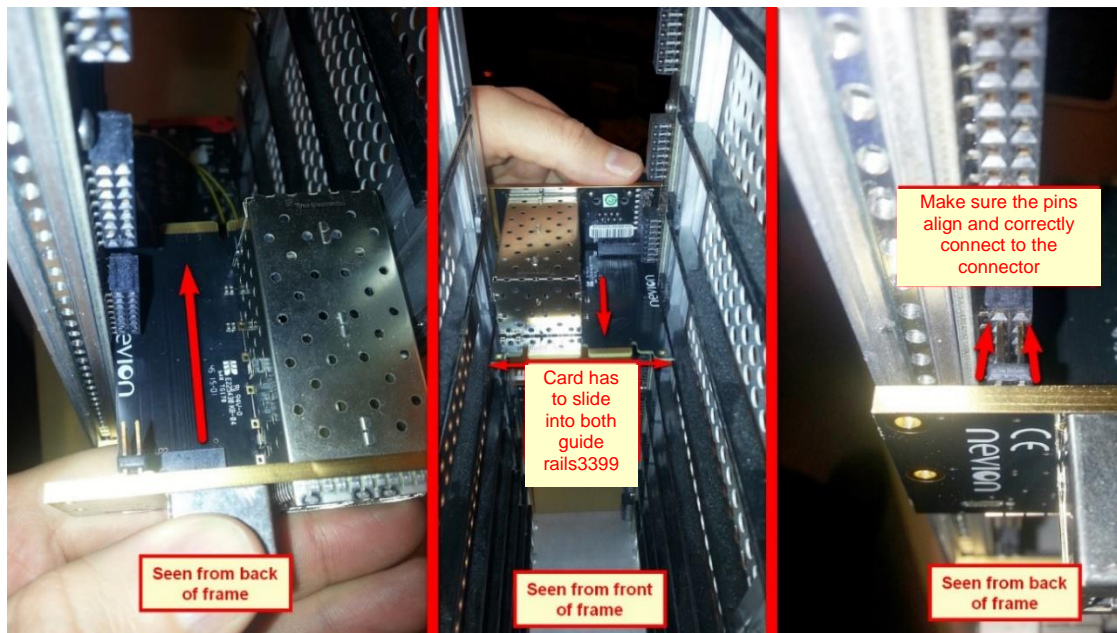

Figure 16: Instalment from the back of the frame
(Remark: Picture of CONV-SFP-4, but the procedure is equal).

4.2 Terminal format support

The different input and output ports on QUAD-CHO-2x1-PB can support a number of formats. The table below shows which signal formats are supported on the selected terminals.

Unused input and output ports should be terminated with 75 Ohm terminators.

Table 2: Signal support

Terminal	Function	Supported Format	Mode
I-xA I/O-xB (x = 1,2,3,4)	Electrical Input	SDI, DVB-ASI, Transparent	Input
O-xA (x = 1,2,3,4)	Electrical Output Reclocked Output	SDI, DVB-ASI, Transparent	Output
GPIO-(2-4)	Status	Wired alarms	Open Drain output
GPIO-5	Module status	Wired alarms	Open Drain output

4.3 GPIO connections

GPI connector is shown in figures below.

Table 3: QUAD-CHO-2x1-PB module GPI pinning

Signal	Function	Pin #	Mode
GPIO-1 / Status	Not used	Pin 1	
GPIO-2	Reflects “Info 1” LED. See also 5.1.2	Pin 2	Open drain
GPIO-3	Reflects “Info 2” LED. See also 5.1.2	Pin 3	Open drain
GPIO-4	Reflects “Info 3” LED. See also 5.1.2	Pin 4	Open drain
GPIO-5	Module status, reflects the “Status” LED. See also 5.1.2	Pin 5	Open drain
Ground	0V / gnd pin	Pin 6	0V



Figure 17: GPI connector

4.4 Passive input bypass (-PB)

The equalized cable lengths specified under chapter [“2.2 Electrical SDI inputs”](#) are valid only when the main board is active and are based on the equalizing properties of the specific cable equalizer solution used in this product.

When utilizing the “Passive input bypass” solution, the sum of cable lengths from the source via the relay inside QUAD-CHO-2x1-PB to the next product in the chain must be dimensioned according to the equalizing properties of this next product.

It is strongly recommended to perform thorough testing of the function before taking it into use.

5 Operation

5.1 Module status

The status of the module can be monitored in three ways.

1. Multicon GYDA System Controller (optional).
2. GPIOs at the rear of the sub-rack.
3. LEDs at the front of the sub-rack.

Of these three, the GPI and the LEDs are mounted on the product itself, whereas the Multicon GYDA System Controller is a separate module giving detailed information on the card status.

5.1.1 Multicon GYDA status interface

Quad CHO 2x1 with Passive Bypass

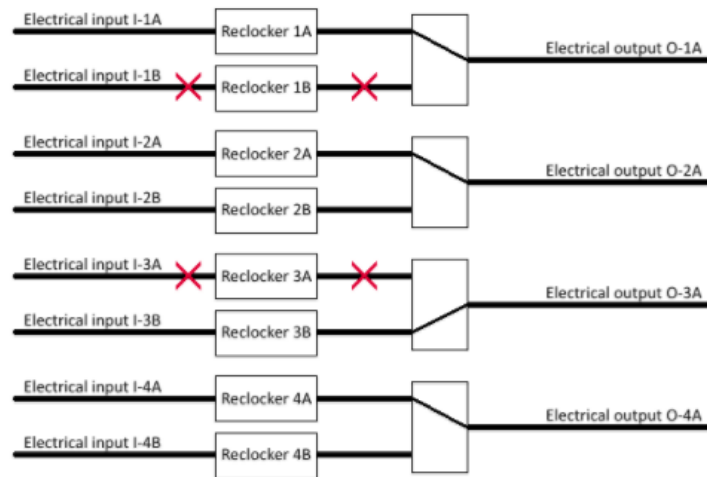

Electrical input I-1A	Normal		Signal detected
Electrical input I-2A	Normal		Signal detected
Electrical input I-3A	Normal		Loss of signal
Electrical input I-4A	Normal		Signal detected
Electrical input I-1B	Normal		Loss of signal
Electrical input I-2B	Normal		Signal detected
Electrical input I-3B	Normal		Signal detected
Electrical input I-4B	Normal		Signal detected
Reclocker 1A	Locked	270 Mbps	SD
Reclocker 2A	Locked	270 Mbps	SD
Reclocker 3A	Loss of lock		
Reclocker 4A	Locked	270 Mbps	SD
Reclocker 1B	Loss of lock		
Reclocker 2B	Locked	270 Mbps	SD
Reclocker 3B	Locked	270 Mbps	SD
Reclocker 4B	Locked	270 Mbps	SD
Automatic change-over 1	El input I-1A		
Automatic change-over 2	El input I-2A		
Automatic change-over 3	El input I-3B		
Automatic change-over 4	El input I-4A		
Supply source	Input		+15V
Supply (+5.2V)	4.94 V (5.2 V)	0.00 A (0.8 A)	0.00 W (4.0 W)
Supply (+15V)	14.72 V (15.0 V)	0.31 A (0.3 A)	4.49 W (4.6 W)
Voltage (1.8V)	1.74 V		
Voltage (3.3V)	3.18 V		
Temperature	47.0 C		

Alarms		
Electrical input I-3A	NEW	Acknowledge
Electrical input I-1B	NEW	Acknowledge
Automatic change-over 3	NEW	Acknowledge
Reclocker 3A	NEW	Acknowledge
Reclocker 1B	NEW	Acknowledge
Card lost	RESTORED	Acknowledge
Acknowledge all 6 alarms	COMMON	Ack all

Figure 18: Status tab example

The on-board temperature measurement is a feature used for monitoring variations in temperature over time and can be accessed thru SNMP. The absolute value of the temperature measurement has little value of its own as it does not reflect the temperature inside the electronics nor the ambient frame temperature.

When +5V is chosen as supply source, the presented current value for +15V will be approximately 0.04A due to current drain of the four high frequency relays.

If a reclocker is configured to "Bypass" mode and a recognizable signal rate is applied, the shown info will be "Locked" and "Actual rate" though the signal is not reclocked. Otherwise the displayed info will be "Bypass" and no rate information.

5.1.2 GPIO ALARM – Module Status Outputs

These outputs can be used for wiring up alarms for third party control systems. All GPIO outputs are of open drain type.

Open drain GPIO (#5) function:

This output is low ohmic referred to GND when no severe system errors are detected and high ohmic in opposite situation and when no main board is connected

Open drain GPIOs (#2-4) function:

These outputs reflect the status on LEDs "INFO 1-3" respectively as follows;

- Low ohmic referred to GND when LED is green or orange
- High ohmic referred to GND when LED is red

Open drain GPIO #5 function:

This output reflects the status on the "Status" LED as follows;

- Low ohmic referred to GND when LED is green
- High ohmic referred to GND when LED is red

5.1.3 Front panel - Status monitoring

The status of the module can be easily monitored visually by the LEDs at the front of the module. The LEDs are visible through the front panel of FR-2RU-10-2(-MkII) as shown in the figure below.

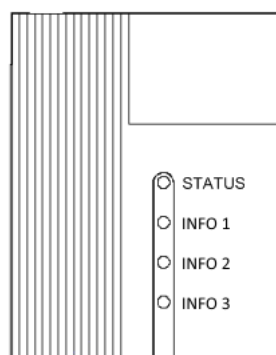

Figure 19: Front panel LEDs

Table 4: Front panel LEDs

LED \ State	Red	Orange	Green	No light	Comment
Status	Module is faulty, or module is initializing	N/A	Module is OK Module power is OK	Module has no power	
INFO 1	All Main Loss Of Lock & Loss Of Signal	1-3 Main Loss Of Lock Or Loss Of Signal	All Main Lock & Signal present	N/A	All Main Input Equalizer and Reclocker alarms OR'ed
INFO 2	All Backup Loss Of Lock & Loss Of Signal	1-3 Backup Loss Of Lock Or Loss Of Signal	All Backup Lock & Signal present	N/A	All Backup Input Equalizer and Reclocker alarms OR'ed
INFO 3	All Backup selected	1-3 Backup selected	All Main selected	Mode not in Auto	All CHO alarms OR'ed

General environmental requirements for Nevion equipment

1. The equipment will meet the guaranteed performance specification under the following environmental conditions:
 - Operating room temperature range: 0°C to 45°C
 - Operating relative humidity range: <90% (non-condensing)

2. The equipment will operate without damage under the following environmental conditions:
 - Temperature range: -10°C to 55°C
 - Relative humidity range: <95% (non-condensing)

Product Warranty

The warranty terms and conditions for the product(s) covered by this manual follow the General Sales Conditions by Nevion, which are available on the company web site:

www.nevion.com

Appendix A Materials declaration and recycling information

A.1 Materials declaration

For product sold into China after 1st March 2007, we comply with the “Administrative Measure on the Control of Pollution by Electronic Information Products”. In the first stage of this legislation, content of six hazardous materials has to be declared. The table below shows the required information.

組成名稱 Part Name	Toxic or hazardous substances and elements					
	鉛 Lead (Pb)	汞 Mercury (Hg)	鎘 Cadmium (Cd)	六价铬 Hexavalent Chromium (Cr(VI))	多溴联苯 Polybrominated biphenyls (PBB)	多溴二苯醚 Polybrominated diphenyl ethers (PBDE)
QUAD-CHO-2x1-PB	○	○	○	○	○	○
<p>O: Indicates that this toxic or hazardous substance contained in all of the homogeneous materials for this part is below the limit requirement in SJ/T11363-2006.</p> <p>X: Indicates that this toxic or hazardous substance contained in at least one of the homogeneous materials used for this part is above the limit requirement in SJ/T11363-2006.</p>						

This is indicated by the product marking:



A.2 Recycling information

Nevion provides assistance to customers and recyclers through our web site <http://www.nevion.com/>. Please contact Nevion’s Customer Support for assistance with recycling if this site does not show the information you require.

Where it is not possible to return the product to Nevion or its agents for recycling, the following general information may be of assistance:

- Before attempting disassembly, ensure the product is completely disconnected from power and signal connections.
- All major parts are marked or labeled to show their material content.
- Depending on the date of manufacture, this product may contain lead in solder.
- Some circuit boards may contain battery-backed memory devices.